

DIN Non-Rising Stem Gate Valve F15 Series PN16/PN25/PN40

Applicable standards

- 1.Design & Manufacture: DIN 3352
2. Face to Face: DIN 3202-F15, EN 558-1
3. End Flange Dimensions: DIN 2543(PN 16), DIN 2544(PN 25), DIN 2545(PN 40), EN 1092-1
4. Pressure Test: DIN 3230, EN 12266-1

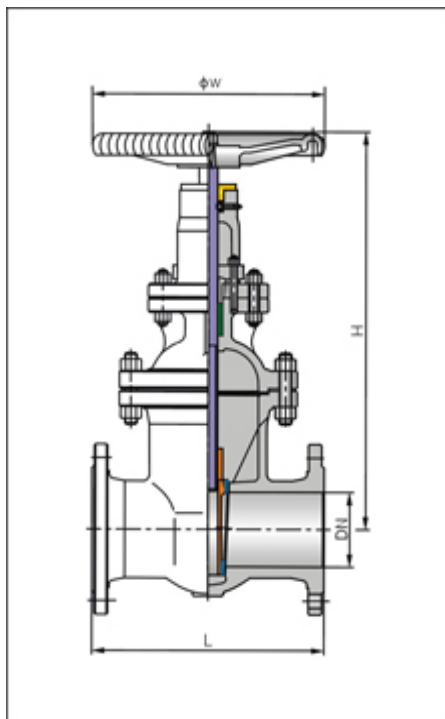

Material of Parts

NO	Part Name	Material	NO	Part Name	Material
1	Body	GS-C25+13CR	14	Gland Flange	GS-C25
2	Disc	GS-C25+13CR	15	Bolt	A193 B7
3	Stem Nut	A439 D0	16	Nut	A194 2H
4	Stem	A182 F6	17	Yoke	GS-C25
5	Gasket	SS304+Graphite	18	Plane Bearing	GCr
6	Bonnet	GS-C25	19	Bisect Cirque	A274 410
7	Bolt	A193 B7	20	Gland Bearing	1035
8	Nut	A194 2H	21	Handwheel	A536
9	Bolt	A193 B7	22	Washer	A3
10	Nut	A194 2H	23	Nut	A194 2H
11	Packing	Braid Graphite	24	Grease Cup	Brass
12	Packing	Flexible Graphite	25	Name Plate	304
13	Gland	A182 F6	26	Rivet	H62

Dimension Data

PN	DN	50	65	80	100	125	150	200	250	300	350	400	mm
16	L	250	270	280	330	360	390	460	530	630	690	750	
	H	305	354	402	437	496	541	699	815	914	1189	1350	
	W	200	200	250	300	300	350	350	400	450	500	550	
25	L	250	270	280	330	360	390	460	530	630	690	750	
	H	325	363	425	453	505	556	744	864	948	1269	1450	
	W	200	200	250	300	350	400	450	500	550	600	600	
40	L	250	270	280	330	360	390	460	530	630	690	750	
	H	325	370	430	480	532	589	783	888	965	1285	1512	
	W	200	200	250	300	350	400	450	500	550	600	600	