

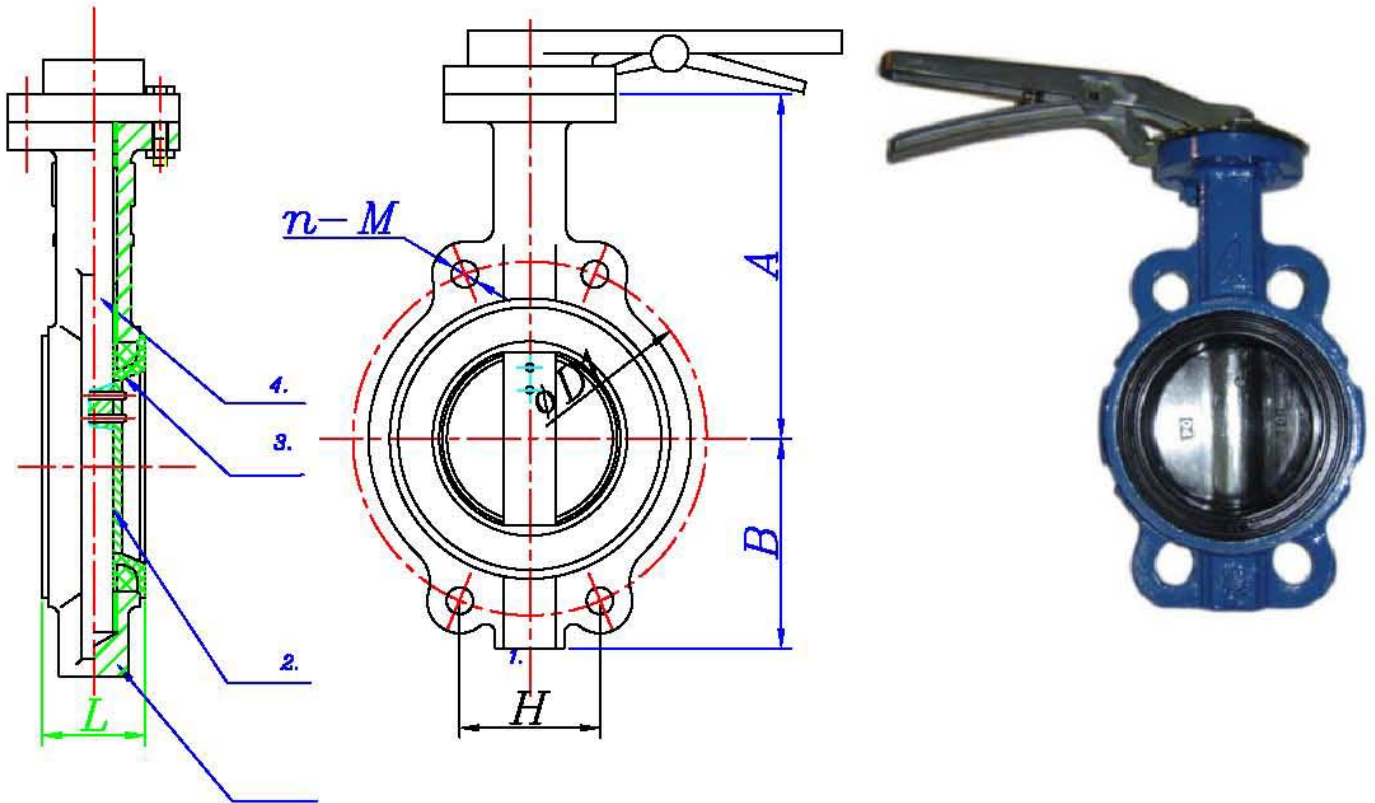

Wafer type butterfly valves

Class 150



4. Spindle	Stainless steel	2Cr13
3. Body seat ring	EPDM	
2. Disc	Ductile iron	BS2789 Gr.500/7
1. Body	Ductile iron	BS2789 Gr.500/7
NO. COMPONENT	MATERIAL	SPEC.

TEST PRESSURE	BODY	24	Bar
	SEAT	17.8	
WORKING PRESSURE		16	
FLOW MEDIUM		WATER	
SUITABLE TEMPERATURE		<=65°	

SIZE	DN	ØD1	n-M	H	A	B	L	weight(kg)
2"	50	120.5	4-M16	85.2	161	80	42	3.3
3"	80	152.5	4-M16	107.8	181	95	45.2	4.2
4"	100	190.5	4-M16	72.9	200	114	52.1	5.7
6"	150	241.5	4-M20	92.4	226	139	55.8	8.6
8"	200	298.5	4-M20	114.2	260	175	60.6	14